

LEGEND

- 120x2.4m VISIBILITY SPLAY
- ENTRANCE DRIVE RAISED BY 300mm

GENERAL NOTES
 ALL DIMENSIONS TO BE CHECKED ON SITE PRIOR TO COMMENCEMENT OF WORKS - PLEASE REPORT ERRORS OR OMISSIONS TO THE ARCHITECT.
 THIS DRAWING HAS BEEN PRODUCED FOR THE PURPOSES OF PLANNING AND BUILDING REGULATION APPROVALS ONLY AND IS NOT INTENDED TO BE A FULL WORKING DRAWING.
 THIS DRAWING IS TO BE READ IN CONJUNCTION WITH ANY WRITTEN SPECIFICATIONS, SCHEDULES OF WORK AND STRUCTURAL ENGINEERS DETAILS AS APPROPRIATE.
 THIS DRAWING IS THE COPYRIGHT OF PUMP HOUSE DESIGNS AND ANY FURTHER REPRODUCTION OF THE PLAN IS NOT PERMITTED WITHOUT OBTAINING PRIOR CONSENT.
 © CROWN COPYRIGHT - LICENCE NO. 10003237

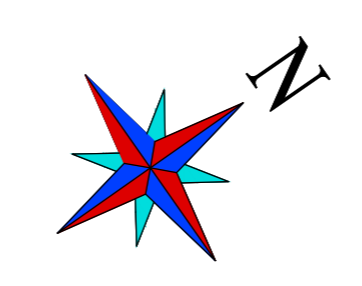

Further Down

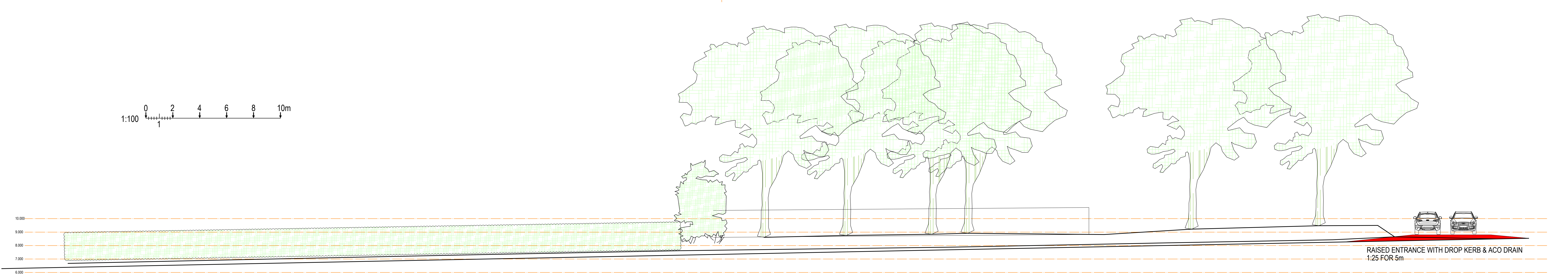
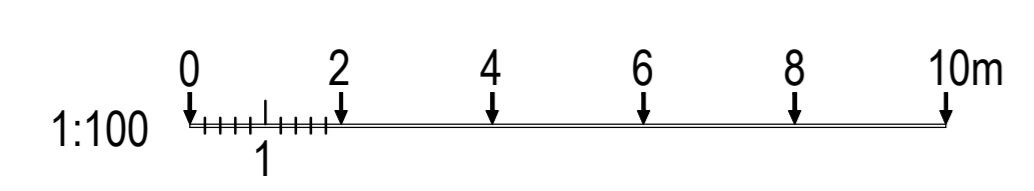
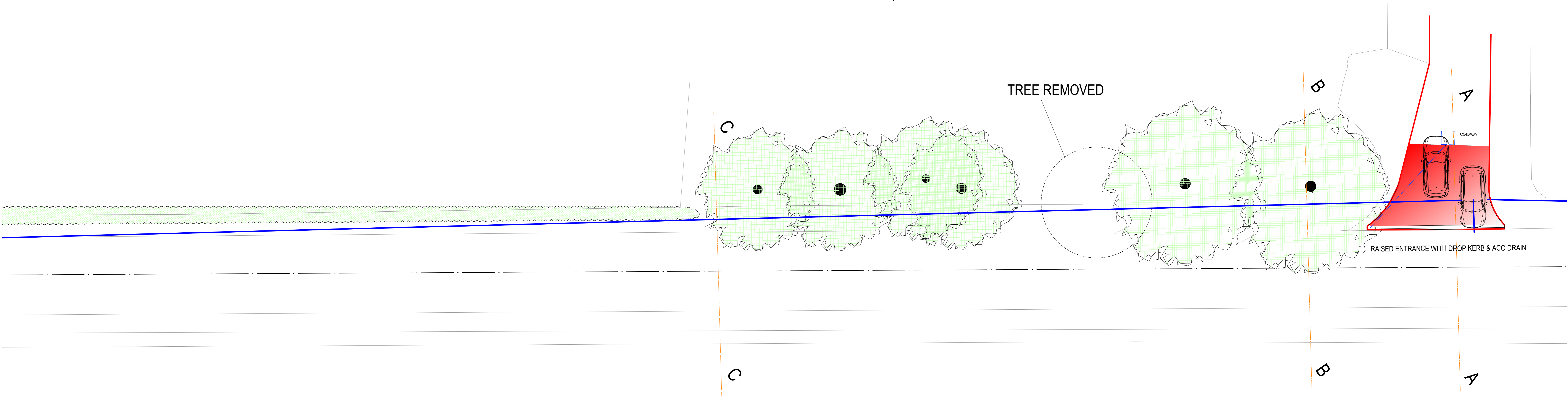

STREET VIEW

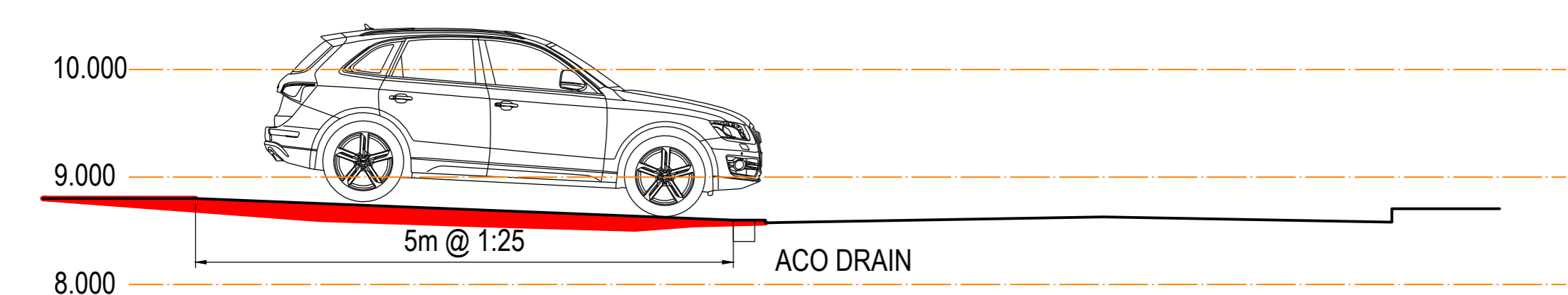
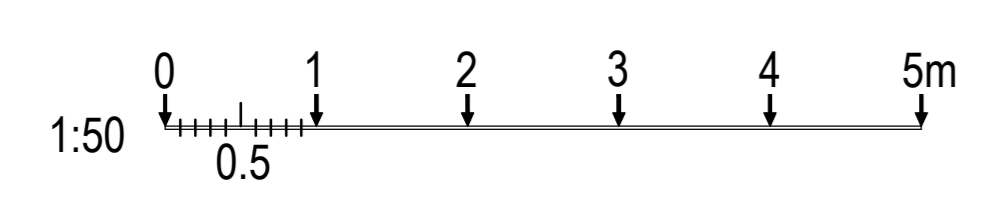

SECTION 'A'

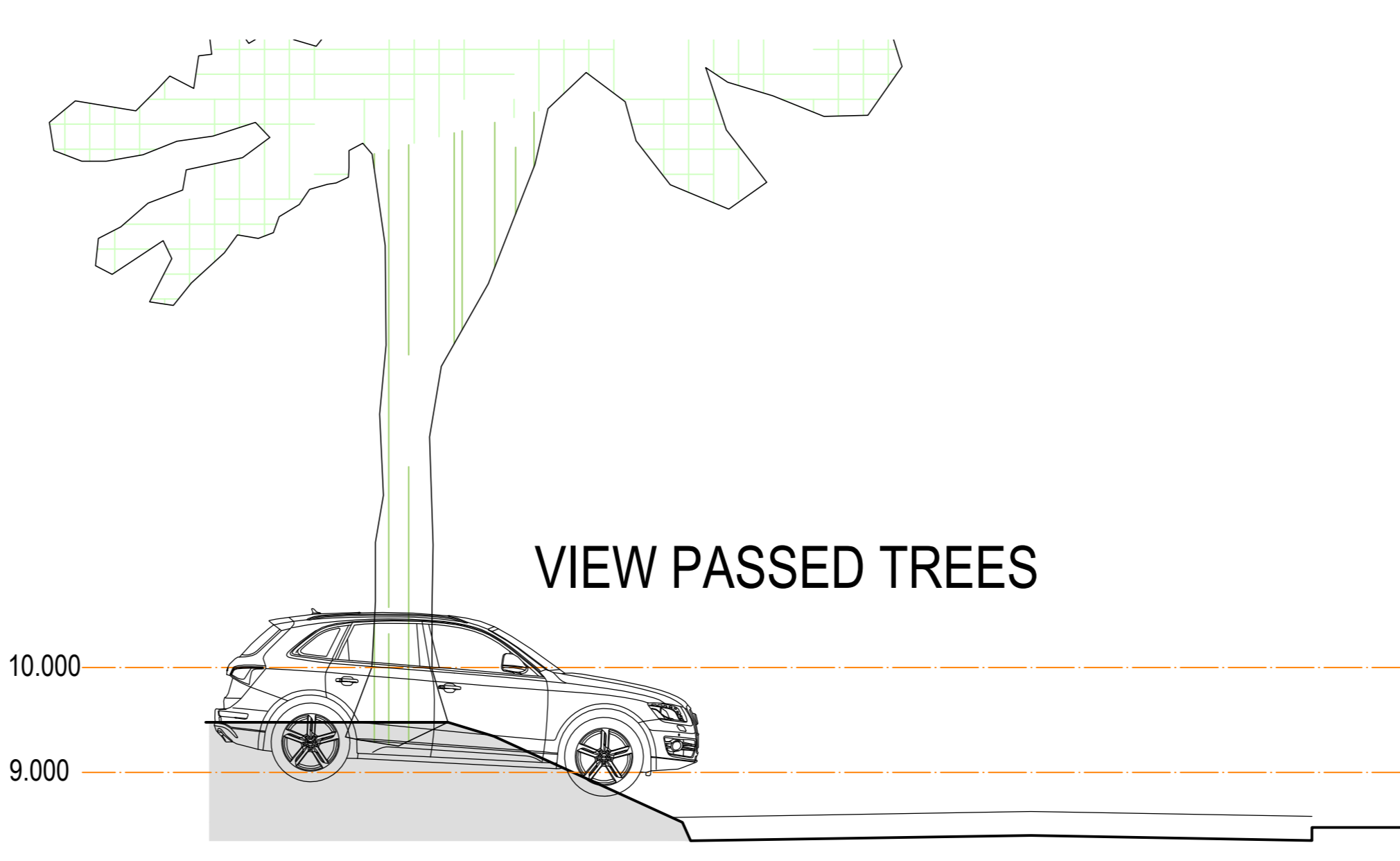

SECTION 'B'

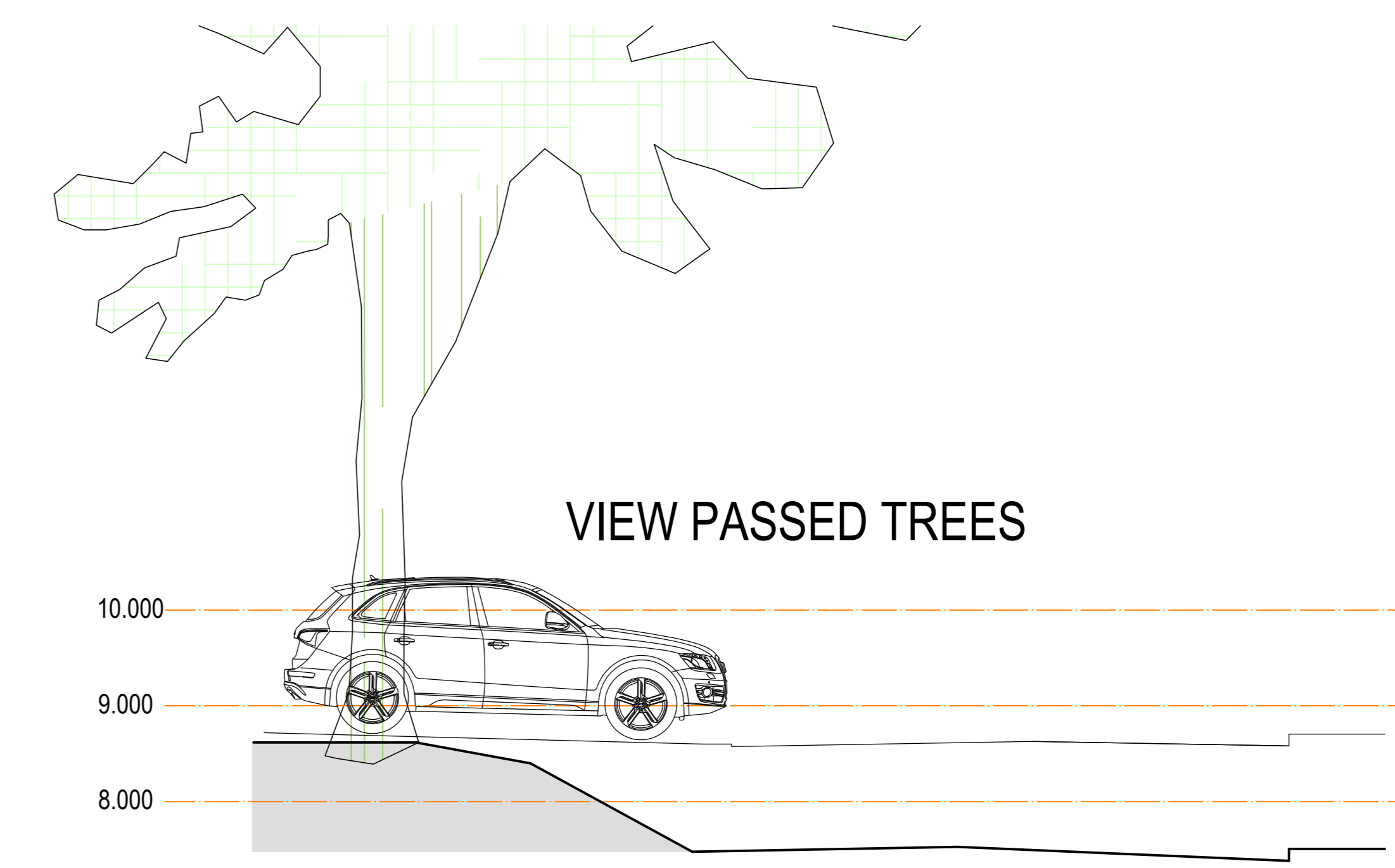

SECTION 'C'

PumpHouse
 DESIGNS
 Architectural & Interior
 Design Consultants

Pump House Yard
 The Green
 Sedgecombe
 East Sussex
 TN33 0QA
 info@pumphousedesigns.co.uk
 www.pumphousedesigns.co.uk

T: 01424 871120

| | | |
|-----|--|-----------|
| REV | DESCRIPTION | DATE |
| 1 | ENTRANCE DETAIL AMENDED TO HIGHWAYS DETAIL | MS 18/021 |
| 2 | ENTRANCE LEVEL AMENDED | MS 19/021 |

**FURTHER DOWN
 MAIN ROAD
 WESTFIELD**
 for Ms K Greenhalgh

VISIBILITY SPLAY

DRAWN BY - MATTHEW GERKEN
 DATE - JANUARY 2021
 SCALE - 1:50 & 1:100 @ A0

DRAWING No. 6375 / 3 / B