

DESIGNER RISK INFORMATION	
IN ADDITION TO THE HAZARDS/RISKS NORMALLY ASSOCIATED WITH THE TYPES OF WORK DETAILED ON THIS DRAWING, NOTE THE FOLLOWING:-	
CONSTRUCTION:	
MAINTENANCE/CLEANING:	
DECOMMISSIONING/DEMOLITION:	
IT IS ASSUMED THAT ALL WORKS WILL BE CARRIED OUT BY A COMPETENT CONTRACTOR WORKING, WHERE APPROPRIATE, TO AN APPROVED METHOD STATEMENT.	
	ACCESS ROAD CARRIAGEWAY 45mm HRA 30/14 C 40/60 PEN TO BS EN 13108-4 60mm AC20 BIN 100/150 PEN TO BS EN 13108-1 100mm AC32 BASE 100/150 PEN TO BS EN 13108-1 150mm TYPE 1 SUB-BASE TO CL.803 350mm 6F2 CAPPING
	ACCESS ROAD BLOCK PAVIORS 80mm BLOCK TO ARCHITECT SPEC 30mm LAYING COURSE (SAND) 130mm AC32 BASE 100/150 PEN TO BS EN 13108-1 150mm TYPE 1 SUB-BASE TO CL.803 350mm 6F2 CAPPING
	FOOTWAY 30mm AC6 SURF 100/150 PEN TO BS EN 13108-1 60mm AC20 BIN 100/150 PEN TO BS-EN 13108-1 150mm TYPE 1 SUB-BASE TO CL.803
	HB2 HALF BATTER KERB
	EF EDGING KERB
	BN BULLNOSE KERB
	CH CHANNEL KERB

SITE ACCESS - DIMENSIONS & LEVELS

SCALE 1:500 @ A1

SITE ACCESS - CONSTRUCTION LAYOUT

SCALE 1:500 @ A1

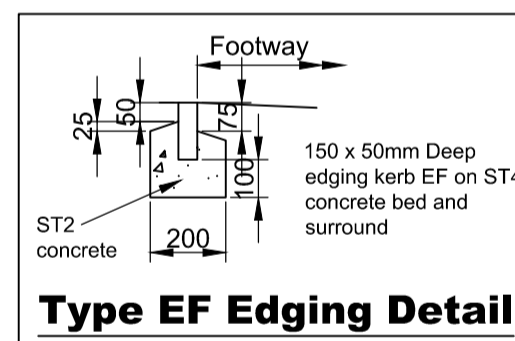
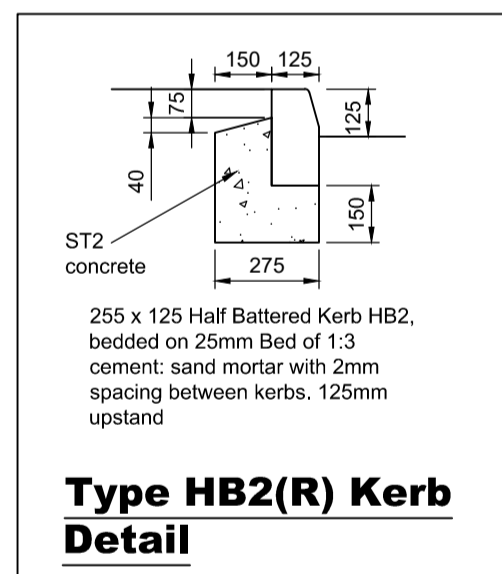
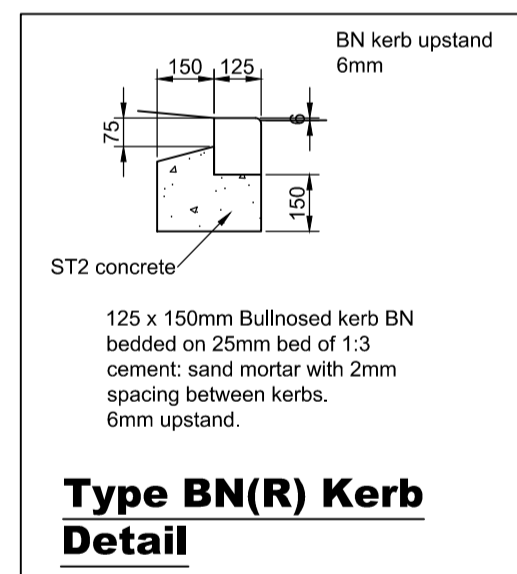

KERBING NOTES
All kerb foundations and backing to be shuttered and constructed in ST2 concrete, poker vibrated in widths of 365mm x 150mm in straight alignments and 525mm x 150mm in 50m radii or less. ST2 min 30mm slump, concrete foundation and haunch. 150mm compacted Type 1 sub-base required under kerb and bedding edging.

Rev	Date	Amendment	MR	TM
P01	28/11/21	ISSUED FOR INFORMATION	MR	TM
Southgate House, 38 Southgate, Wakefield WF1 1TL T: 01924 811 000 mjm.co.uk				
Project: CAPEL STREET				
Client: BLUR STUDIO LTD.				
Drawing Title: SITE ACCESS - GENERAL ARRANGEMENT				
MR	TM	TM		
MJM Ref:	Scale:	Sheet Size:		
8202	1:500	A1		
Revision Status:	Suitability Status:	Date:		
P1	S2	NOV '21		
Suitability Description: FOR INFORMATION				
Drawing Reference: Project - Originator - Zone - Level - File Type - Discipline - Number				
8202-MJM-XX-XX-DR-H-1001				

© THIS DRAWING MAY NOT BE COPIED, REPRODUCED, OR TRANSMITTED IN ANY FORM OR BY ANY MEANS, WITHOUT PRIOR WRITTEN PERMISSION